

## For Commercial and Industrial Applications

Job Name \_\_\_\_\_

Contractor \_\_\_\_\_

Job Location \_\_\_\_\_

Approval \_\_\_\_\_

Engineer \_\_\_\_\_

Contractor's P.O. No. \_\_\_\_\_

Approval \_\_\_\_\_

Representative \_\_\_\_\_

# Models OF1465-50 and OF1665-75

## OneFlow™ Anti-Scale System

### Connection Sizes: 2" (50mm)

### Flow Rates: From 30 gpm to 450 gpm (114 lpm to 1703 lpm)

The OneFlow™ Anti-Scale System provides protection from scale formation on internal and external plumbing surfaces. The OneFlow™ system may be installed at the point-of-entry to a building to treat both hot\* and cold water, or it can be located directly before a water heater, boiler, or other hot water-using device that requires protection from the ill effects of hard water.

OneFlow™ prevents scale by transforming dissolved hardness minerals into harmless, inactive microscopic crystal particles, as water travels through the media filled tank. These precipitated micro-crystals stay suspended in the water and are passed to drain, thereby having a greatly reduced ability to react negatively like dissolved hardness does. The system requires very little maintenance, no backwashing, no salt, and no electricity. Typical hardness problems, especially build-up of scale in pipes, water heaters, boilers and on fixtures are no longer a concern.

OneFlow™ is not a water softener or a chemical additive (like anti-scalants or sequestrants). It is a scale prevention device with proven third party laboratory test data and years of successful residential and commercial applications. OneFlow™ is the one water treatment device that effectively provides scale protection and is a great alternative to water softening (ion exchange) or scale sequestering chemicals.

### Features

- Chemical-free scale prevention and protection – converts hardness minerals to harmless, inactive microscopic crystals making OneFlow™ an effective alternative technology to a water softener for the prevention of scale due to water hardness
- Virtually maintenance free – No salt bags or other chemicals to constantly add
- No control valve, no electricity and no wastewater
- Uses environmentally friendly “green” technology
- Improves efficiency of all water using appliances – both hot\* and cold
- Simple sizing & installation – all you need to know is pipe size and the peak flow rate
- Perfect system for towns or communities where water softeners are banned or restricted
- Manifold assemblies for easy installation of multi-tank, high-flow applications (Can be operated in parallel for high flow applications.)
- OneFlow™ does not remove minerals or add sodium to the water supply
- OneFlow™ can be installed as pre-treatment to reverse osmosis (OneFlow™ should be the last stage in treatment unless a point-of-use system is being used down stream.)

\* For hot water applications where water temperature is 110°F – 150°F, please consult ES-OneFlow-HotWater



OF1665-75

Watts product specifications in U.S. customary units and metric are approximate and are provided for reference only. For precise measurements, please contact Watts Technical Service. Watts reserves the right to change or modify product design, construction, specifications, or materials without prior notice and without incurring any obligation to make such changes and modifications on Watts products previously or subsequently sold.

**WATTS®**

## Models

Model	Maximum Flow Rate
OF1465-50	50 gpm (189.3 lpm)
OF1665-75	75 gpm (283.9 lpm)

## Connections

Inlet Connection	2" (50mm) PVC Union with 90° Socket
Outlet Connection	2" (50mm) PVC Socket

## Replacement Media

OF1465RM	Media should be replaced every 3 years
OF1665RM	Media should be replaced every 3 years

## Specifications

A OneFlow™ scale prevention system shall be installed on the main water service pipe just after it enters the building, but after other whole building water safety devices (backflow preventers or pressure reducing valves), to effectively address water hardness concerns. A system may also be installed further downstream to protect specific equipment or areas within a plumbing system. The system shall be plumbed with a bypass valve to allow isolation of tank(s) and to allow the bypass of untreated water in the event that service or media replacement be necessary. The installation area should be suitable in size for the tank(s) to be serviced without encumbrance and sit upright on a flat level surface.

The system must operate in an upflow manner and not require additional water to backwash, flush, or regenerate once put into service. The system must not require any chemical additives and must not require electricity for operation.

Multi-tank systems shall be installed in parallel with PVC/CPVC manifold to meet peak flow rate requirements.

## Feed Water Chemistry Requirements

pH	6.5 to 8.5
Hardness (maximum)	75 grains (1300 ppm CaCO <sub>3</sub> )
Water Pressure	15psi to 100psi (103 kPa to 6.9 bar)
Temperature	40°F to 110°F (5°C to 43°C)
Chlorine	< 3ppm
Iron (maximum)	0.3 mg/l
Manganese (maximum)	0.05 mg/l
Copper (maximum)	1.3 mg/l
Oil & H <sub>2</sub> S	None allowed
Polyphosphate	None allowed
Silica (maximum)	10 ppm

**Note:** Water known to have heavy loads of dirt and debris should be strained prior to OneFlow™ using a wye-pattern strainer (100 mesh) or equivalent.

## Dimensions

Model	Dimensions									
	A		B		C		D		E	
	in.	mm	in.	mm	in.	mm	in.	mm	in.	mm
OF1465-50	17	432	14	356	79	2006	65	1651	10 <sup>3</sup> / <sub>4</sub>	260
OF1665-75	17	432	16	406	79	2006	65	1651	10 <sup>1</sup> / <sub>2</sub>	267

The overall height and the height of the inlet fitting varies due to material variations and assembly tolerances. Please allow additional clearance above the tank for making connections.

# WATTS®

Water Safety & Flow Control Products

ES-OF1465\_1665 0738

## Standards

DVGW – German Technical and Scientific Association for Gas & Water

OneFlow™ meets standard W-512 for testing Physical Water Treatment devices for Scale Prevention and achieved an efficiency rating of 99.6% for scale prevention.

OneFlow™ media has been tested and certified for material safety to NSF/ANSI Standard 42 and 61.

## Peak Flow Rates - Weights

	OF1465		OF1665	
Dry Weight	54 lbs.	31.8 kgs.	88 lbs.	30.8 kgs.
Service Weight	350 lbs.	158.8 kgs.	420 lbs.	190.6 kgs.

Multi-Tank Connection		Maximum Flow Rate*	
Qty	Models	gpm	lpm
1	OF1465-50	50	189.3
1	OF1665-75	75	283.9
2	OF1465-50	100	378.5
2	OF1665-75	150	567.8
3	OF1665-75	225	851.7
5	OF1465-50	250	946.4
4	OF1665-75	300	1135.6
5	OF1665-75	375	1419.5
6	OF1665-75	450	1703.4

\* Exceeding maximum flow can reduce effectiveness and void warranty.

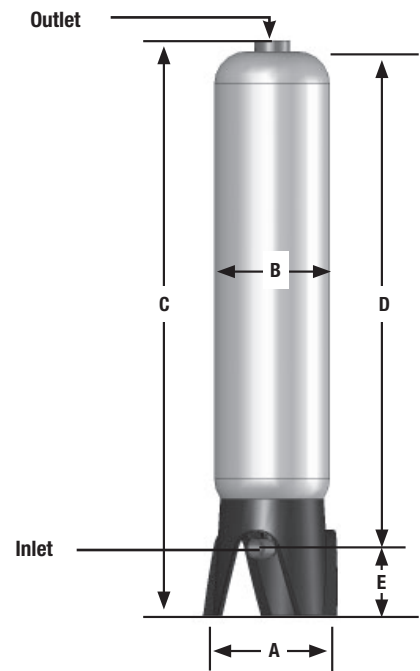

ISO 9001  
CERTIFIED

USA: 815 Chestnut St., No. Andover, MA 01845-6098; www.watts.com

Canada: 5435 North Service Rd., Burlington, ONT. L7L 5H7; www.wattscanada.ca

©Watts Regulator Company, 2007